

Ref. : VG 6400-00.pas

Rev. : M

Date : 29/04/2014

Page : 1/1

KNIFE GATE VALVE WITH HANDWHEEL

VG 6400-00



APPLICATION

General use : Pulp production, water, water treatment, waste water, chemical industry (powdery or crystallizing products), wine-producing, pulverized products (cement work, pneumatic transport, stocking).

GENERAL CHARACTERISTICS

Range : from DN 50 up to DN 600.
 Function ON/OFF or regulation.
 Wafer threaded mounting ISO PN10.
 Unidirectional tightness, direction indication thanks to the arrow on the body.
 Small retention zone : the gate is guided in the body and has little clearance.
 Gland assembly: packing and O-ring (same material as seat joint) to assure the elasticity and decrease the operating torque.
 Small head loss.
 Possibility to regulate thick fluids with the adaptation of a diaphragm ring .



CONSTRUCTION

17	1	O-Ring	EPDM	
16**	1	Support ring	Stainless steel 316	DIN : X5CrNiMo18 10 ASTM : A 182 AISI316 BS : 316 S16
15**	1	Gasket	EPDM	
14	1	Packing gland	Stainless steel	DIN : G-X6CrNiMo18 10 ASTM : A 351 grade CF8M BS : 316 C16
13	1	Handwheel	Cast iron EN-GJL-250	DIN : GG25 ASTM : A 48 class 40B BS : 1452 grade 250
12	1	Protection tube	Steel	
11	1	Cap	Plastic	
10	1	Greaser	Stainless steel	
9	1	Stop screw	Stainless steel	
8	1	Nut support	Bronze	
7	1	Friction washer	Bronze	
6	1	Nut support	Zinc steel	
5*	2	Support plate	Steel + epoxy	
4	1	Stem	Stainless steel 13%Cr	
3	1	Gate	Stainless steel X5CrNiMo 17-12-2	DIN : X5CrNiMo18 10 ASTM : A 182 AISI316 BS : 1449-2316 S16
2	2	Packing	PTFE	
1	1	Body	Stainless steel GX5CrNiMo 19-11-2	DIN : G-X6CrNiMo18 10 ASTM : A 351 grade CF8M BS : 316 C16
Pos.	Qty.	Description	Material	

* Pre-shaped parts up to DN 300.
 ** Missing parts on metal / metal tightness

DIMENSIONS

DN		A	B	C	D	ØV	H	ØK	n	ØM	Weight (kg)
mm	inch										
50	2"	40	283	124	83	200	348	125	4	4 x M16	7,5
65	2 1/2"	40	308	139	83	200	388	145	4	4 x M16	8,8
80	3"	50	333	154	83	200	413	160	8	4 x M16	9,4
100	4"	50	378	174	83	200	488	180	8	4 x M16	11,5
125	5"	50	423	189	93	250	564	210	8	4 x M16	15,4
150	6"	60	474	220	93	250	635	240	8	4 x M20	18,5
200	8"	60	593	275	108	310	809	295	8	4 x M20	34,8
250	10"	70	685	326	108	310	946	350	12	8 x M20	47,0
300	12"	70	792	380	108	310	1118	400	12	8 x M20	61,0
350	14"	96	900	438	290	500	1282	460	16	10 x M20	117,0
400	16"	100	978	494	290	500	1441	515	16	10 x M24	151,0
450	18"	106	1105	547	290	500	1587	565	20	14 x M24	187,0
500	20"	110	1215	613	290	500	1809	620	20	14 x M24	205,0
600	24"	110	1418	716	290	500	2060	725	20	14 x M27	292,0

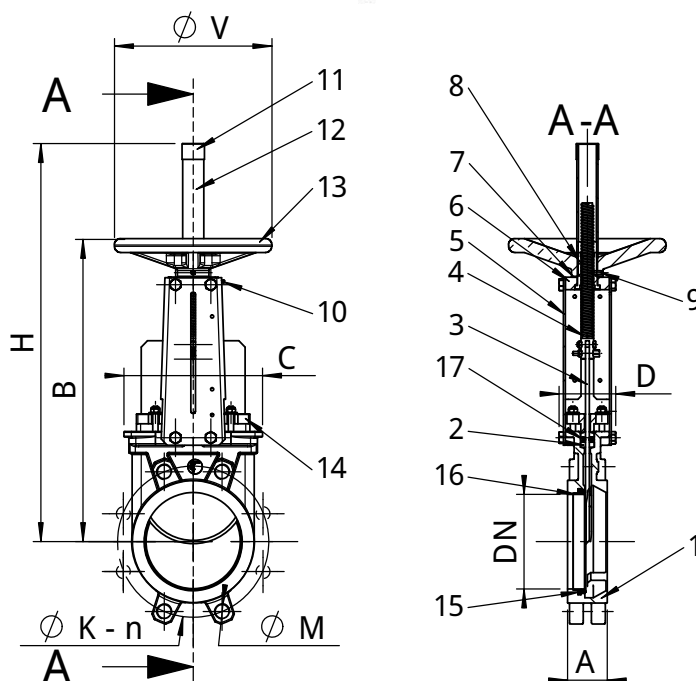

WORKING CONDITIONS

Maximum working pressure : DN 50-250 : 10 bar
 DN 300-450 : 7 bar
 DN 500-600 : 4 bar

Maximum temperature : -10°C / +130°C (standard tightness).

Others materials on request (if marked)	Maximum temperature	
Metal / metal	T max : -10°C / +130°C.	<input type="checkbox"/>
NBR	T max : -10°C / +80°C.	<input type="checkbox"/>
White EPDM	T max : -10°C / +130°C.	<input type="checkbox"/>
Silicone	T max : -10°C / +170°C.	<input type="checkbox"/>
FPM (Type Viton®)	T max : -10°C / +170°C.	<input type="checkbox"/>
PTFE	T max : +4°C / +170°C.	<input type="checkbox"/>
CSM (Type Hypalon®)	T max : +4°C / +80°C.	<input type="checkbox"/>

STANDARDS

Manufacture according to the requirements of the European directive 97/23/CE «Equipments under pressure» : modulate H.
 On request : Product in accordance to european directive "Potentially explosive atmospheres" N° 94/9/EC:
 ATEX II 2 GD c and ATEX II 3 GD c.
 Test procedures are established according to standard EN 12266-1, DIN 3230, BS 5154 and ISO 5208
 Connections according to standard EN 1092-2 and DIN 2501 : ISO PN10.

TECOFI France - 83, Rue Marcel Mérieux 69960 Corbas - FRANCE
 Tél. +33 (0) 4 72 79 05 79 - Fax +33 (0) 4 78 90 19 19 / +33 (0) 4 72 79 05 70
 Adresses e-mail : sales@tecofi.fr ; tecofi@tecofi.fr / Site web : www.tecofi.fr