

Ref. : CA 3241.pas

Rev. : I

Date : 13/04/2016

Page : 1/1

FLANGED TYPE AXIAL CHECK VALVE

CA 3241



APPLICATION

General uses: pumping, irrigation, industry, clean water.

GENERAL CHARACTERISTICS

From DN 50 to DN 300.
Fabrication according to EN 12334.
Excellent tightness.
Low head loss.
Extremely reliable.
Excellent hydraulic result.
Simplicity in mounting and use.

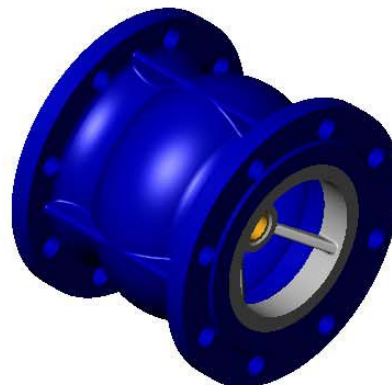

CONSTRUCTION

6	1	Disc	Ductile iron EN-GJS-400-15	DIN: GGG40 ASTM: A536 65-45-12 BS: EN-JS1030
5	1	Seal	Nitril	
4	1	Spring	Stainless steel 316	
3	2	Guiding stem	F4	
2	1	Guide	Ductile iron EN-GJS-400-15	DIN: GGG40 ASTM: A536 65-45-12 BS: EN-JS1030
1	1	Body	Cast iron EN-GJL-250	DIN: GG25 ASTM: A48 class 40B BS: 1452 Grade 250
Pos.	Q-ty	Description	Material	

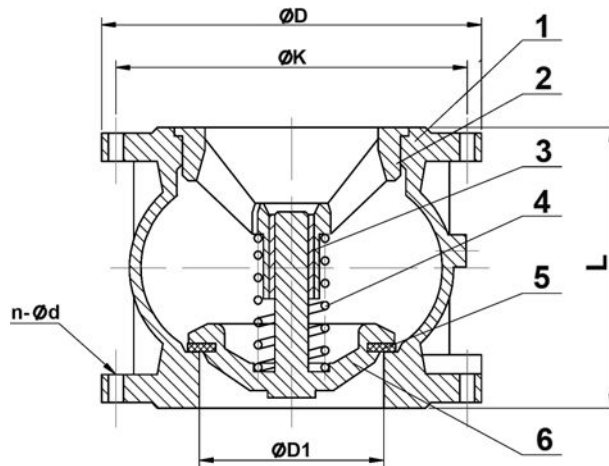

DIMENSIONS

DN		L	Ø D	Ø K	Ø D1	n x Ø L	Weight (kg)
mm	inch						
50	2"	100	165	125	50	4 x 19	5,09
65	2 1/2"	120	185	145	65	4 x 19	7,85
80	3"	140	200	160	80	8 x 19	9,53
100	4"	170	220	180	105	8 x 19	13,2
125	5"	200	250	210	127	8 x 19	20,5
150	6"	230	285	240	145	8 x 23	29,6
200	8"	301	340	295	194	12 x 23	47,3
250	10"	370	405	355	245	12 x 26.5	68
300	12"	410	460	410	300	12 x 26.5	112

WORKING CONDITIONS

Maximum working pressure : 16 bar.
Maximum temperature : +100°C.

Pressure test according to standards
EN 12266-1, DIN 3230, BS 6755 and ISO 5208 :
Body : 24 bar.
Seat : 17,6 bar.

STANDARDS

Flanges drilled according to EN 1092-2 and
DIN 2501/1 : ISO PN16. ASA 150 on request.

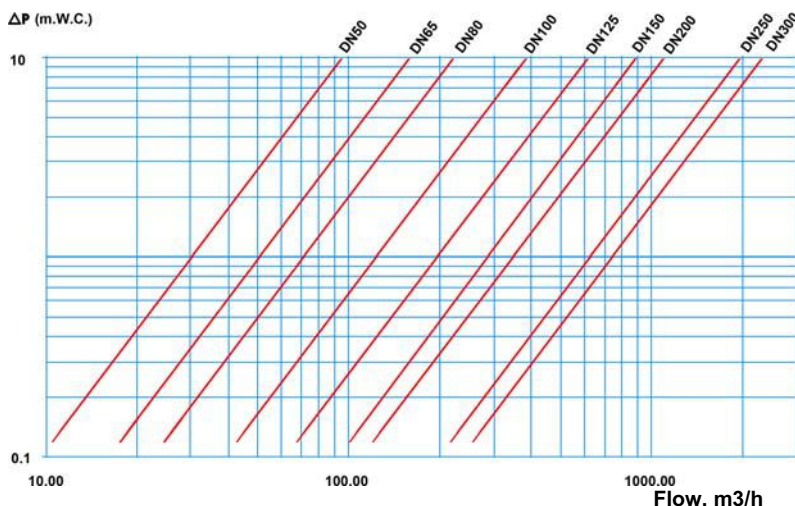

TECOFI France - 83, Rue Marcel Mérieux 69960 Corbas - FRANCE
Tél. +33 (0) 4 72 79 05 79 - Fax +33 (0) 4 78 90 19 19 / +33 (0) 4 72 79 05 70
Adresses e-mail : sales@tecofi.fr ; tecofi@tecofi.fr / Site web : www.tecofi.fr